

# MOTOMA POWER

---

## TECHICAL SPECIFICATION FOR LITHIUM MANGANESE DIOXIDE BATTERY

### CR123A

PREPARED: Yang  
APPROVED: Lu  
DATE : 2008/03/07  
FILE NO : DSE-CR123A-V08A  
VER. : V08A  
PLACE : SHENZHEN • CHINA

---

MOTOMA POWER CO., LTD. SHENZHEN  
<http://www.motoma.cn>

## 1. SCOPE

This specification shall be applied to MOTOMA consumer lithium manganese dioxide battery of CR123A. The all technical data and materials list are for the consumer purpose only.

**TYPE:** CR123A

## 2. APPLICATION

- 2.1 Cameras
- 2.2 Medical treatment instrument
- 2.3 Electronic lock
- 2.4 Lights
- 2.5 Radio
- 2.6 Electronic meter (water meter, gas meter, ammeter etc)
- 2.7 Power source of memory backup meter

## 3. CHARACTERISTICS

- 3.1 Normal voltage: 3.0V
- 3.2 Off-load voltage:  $\geq 3.2V$
- 3.3 Capacity
  - 3.3.1 Normal capacity: 1250mAh (continuously discharged under 10mA current till 2.0V end-voltage at the temperature of  $23\pm 3^{\circ}C$ )
  - 3.3.2 1200mAh (continuously discharged under 50mA current till 2.0V end-voltage at the temperature of  $23\pm 3^{\circ}C$ )
  - 3.3.3 900mAh (continuously discharged under 1000mA current till 1.5V end-voltage at the temperature of  $23\pm 3^{\circ}C$ )
- 3.4 Discharge current
  - 3.4.1 Max. constant current: 1000mA
  - 3.4.2 Max. pulse current: 3000mA
- 3.5 Weight (approx): 16.0g
- 3.6 Storage relative humidity: 45~85%
- 3.7 Temperature characteristic
  - 3.7.1 Storage temperature range:  $-40\sim +60^{\circ}C$
  - 3.7.2 Operate temperature range:  $-40\sim +60^{\circ}C$
  - 3.7.3 Temperature characteristic: see table 1

Table 1 Temperature characteristics table

Project	Condition	Test temperature	Characteristics	
Off-load voltage		23±3℃	≥3.20V	
		-20±3℃	≥3.20V	
		60±3℃	≥3.20V	
On-load voltage	15Ω /5 秒	23±3℃	≥2.60V	
		60±3℃	≥2.60V	
Service output	Continuously discharged under 10mA till 2.0V end-voltage	23±3℃	Standard	1200mAh
			Min. value	1000mAh
		-20±3℃	Standard	800mAh
			Min. value	700mAh
		60±3℃	Standard	1200mAh
			Min. value	1000mAh

3. DIMENSION AND CUTAWAY VIEW: As follows Fig.1

Fig.1 dimension (mm)

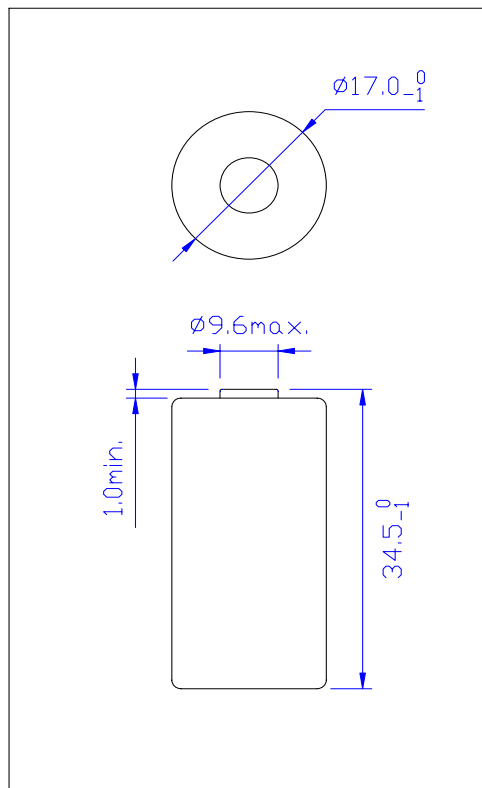

4. APPEARANCE PERFORMANCE

## 4.1 TEST REQUIREMENTS

4.1.1 Initial Test: Means the test begin in one month after the cell produced.

4.1.2 Testing Conditions (unless otherwise specified):

- Temperature:  $25 \pm 15^{\circ}\text{C}$
- Relative Humidity:  $65 \pm 20\%$

4.1.3 Test facility

4.1.3.1 Outer micrometers

Instruments which tolerance shall be  $\pm 0.02\text{mm}$  or below and those having equal or better accuracy shall be used.

4.1.3.2 DC voltmeters

Precision is 0.25 rate or better and the input resistor shall be  $10\text{M}\Omega$  or more.

4.1.3.3 Exactitude resistance

Relative error is 0.5% or below.

4.1.3.4 Resistance box

Relative error is 0.5% or below.

4.1.3.5 Constant temperature and humidity box

Tolerance shall be  $\pm 1.5^{\circ}\text{C}$  or below.

4.1.3.6 Battery program control test system

Tolerance shall be  $\pm 0.3\%$  or below.

## 4.2 TEST METHOD AND PERFORMANCE

4.2.1 Appearance

The appearance of batteries shall be inspected by visual means. The superficies of the cells are clean. The mark is clear. The batteries shall have no deformation, dent, stain, leakage and camber which influence the value of the battery.

4.2.2 Dimensions

Dimensions shall be measured with instruments specified in subparagraph 4.1.3. The result must conform to Fig.1.

4.2.3 Voltage (off-load and on-load voltage)

The samples shall be kept standing open for 7 days or longer at a temperature of  $25 \pm 15^{\circ}\text{C}$ , and the voltage between both terminals at a temperature of  $23 \pm 3^{\circ}\text{C}$  shall be measured with a voltmeter specified in subparagraph 4.1.3. The result must conform to table 1.

4.2.4 Service output

The samples shall be kept for 24h or longer at a temperature

of  $23\pm 3^{\circ}\text{C}$ , and then shall be continuously discharged at  $23\pm 3^{\circ}\text{C}$  under 10mA to 2.0V current end-voltage. The result must conform to table 1.

#### 4.2.5 Leakage characteristics

The samples shall be stored for 7 days or more at a temperature of  $70\pm 2^{\circ}\text{C}$  and a relative humidity of  $70\pm 2\%RH$ , then take a view of them at a temperature of  $25\pm 15^{\circ}\text{C}$ , a relative humidity of  $65\pm 20\%RH$ , there must be no leakage cells.

#### 4.2.6 Terminals

The terminals have a nicer conductibility. There is no rust or leakage within the term of recommend use.

### 5. SUGGESTION & ADVICE

5.1 Never short the positive and negative terminals of the battery. Short-circuiting may cause battery discharge under great current and heat generation from the battery or explosion.

5.2 Never throw the battery into fire and heat battery. Above  $85^{\circ}\text{C}$  environment may cause gasket distortion and leakage, fire or explosion.

5.3 Never solder the body of the battery directly for long time. Solder the body of the battery directly may cause heat generation from the battery or explosion and leakage.

#### 5.4 Never charge

Charging may cause gas evolution or internal short circuiting, followed by fire or explosion.

#### 5.5 Never over-discharge

Force-discharging by external power source or other batteries connected in a series may cause explosion / leakage / heat generation or expend.

#### 5.6 Never disassemble

Dissemble of the battery can cause battery distortion followed by exposing

#### 5.7 Never use old and new batteries together

Using old and new batteries together may load to charging or over-discharging because of the differences in voltage or capacity, followed by explosion/ leakage/ heat generation or expend.

5.8 Never reverse the positive and negative terminals when mounting the battery. The improper connection of the battery may

lead to short-circuiting, charging or forced-discharging, followed by heat generation or explosion.

### 5.9 Never swallowed by mistake

Keep the batteries away from children. If batteries are swallowed by mistake, immediately contact a doctor.

### 5.10 Never throw away battery random.

## 6. TECHNICAL CURVES

