

MOTOMA POWER

TECHICAL SPECIFICATION FOR HIGH POWER
NICKEL CADMIUM RECHARGEABLE BATTERY

NI-CD SC1800P

PREPARED: Yang

APPROVED: Lu

DATE : 2007/12/07

FILE NO : DSE-NC-SC1800P-V07A

VER. : V07A

PLACE : SHENZHEN • CHINA

MOTOMA POWER CO., LTD. SHENZHEN

<http://www.motoma.cn>

1. APPLICATIONS

This specification shall be applied to MOTOMA industrial nickel cadmium rechargeable battery of SC1800P. The all technical data and materials list are for the industrial purpose only.

TYPE : NI-CD SC1800P

APPLICATION: Cordless Power Tools, Toys, Rechargeable Torch, etc.

2. CHARACTERISTICS

2.1 Normal voltage: 1.2V

2.2 Normal capacity: 1800mAh (0.2C).

2.3 Standard charge: 180mA×15hrs.

2.4 Quick charge: 1800mA×1.5hrs ($-\Delta V=5 \sim 20\text{mV}$).

2.5 Trickle charge: 54-90mA.

2.6 Discharge cut-off voltage: 1.0V (20°C).

2.7 Operate temperature range. (Max relative humidity: 85%)

Standard charge 0 ~ +40°C

Trickle charge 10 ~ +45°C

Quick charge 10 ~ +40°C

Discharge -10 ~ +50°C

2.8 Storage temperature range. (Max relative humidity: 85%)

Within one year -10 ~ +30°C

Within three months -10 ~ +40°C

2.9 Weight (approx): 44 (g).

3. DIMENSION: See the Appendix 1

4. APPEARANCE PERFORMANCE

4.1 TEST REQUIREMENTS

The following conditions are for fresh batteries (within one month after production under the test method of 4-2-2.)

Environmental Temperature: +15 ~ +25°C

Relative humidity: 45% ~ 85%.

4.2 TEST METHOD AND PERFORMANCE

4.2.1 APPEARANCE

No conspicuous stretches which influence the value of the battery.

4.2.2 CAPACITY

Charge at 0.1C for 15hours then discharge at 0.2C to the end-voltage 1.0V, the capacity shall be more than 1800mAh.

4.2.3 OPEN-CIRCUIT VOLTAGE

The open-circuit voltage within one hour after full charge shall be more than 1.25V.

4.2.4 INTERNAL IMPEDANCE

Within one hour after full charge, the internal impedance shall be less than 10mΩ/cell.

4.2.5 HIGH RATE DISCHARGE

The capacity shall be more than 5.1minutes with the constant discharge current of 10C to the end voltage of 0.8V after the battery is fully charged.

4.2.6 SELF-DISCHARGE

The capacity shall be ≥ 1080 mAh after the storage at room temperature of 28 days for the fully charged battery.

4.2.7 OVER-CHARGE

The battery shall not cause discoloration, electrolyte, leakage or deformation when charged at 180mA for 48 hours and the capacity shall be more than 1800mAh.

4.2.8 OVER DISCHARGE

The battery shall not cause discoloration, electrolyte, leakage or deformation when it is discharged for 24 hours with the external resistance at 0.25Ω.

4.2.9 LIFE-SPAN (CUSTOM)

The capacity shall be $\geq 1080\text{mAh}$ after 500 cycles with the test conditions as follow:

TEST CONDITION

Cycle life	Charge	Rest	Discharge
1	Charge at $0.1C_5$ for 16 hrs	None	Discharge at $0.25C_5$ for 2.33 hrs.
2~48	Charge at $0.25C_5$ for 3.17 hrs	None	Discharge at $0.25C_5$ for 2.33 hrs.
49	Charge at $0.25C_5$ for 3.17 hrs	None	Discharge at $0.2C_5$ to 1.0V
50	Charge at $0.1C_5$ for 16 hrs	1~4 hrs.	Discharge at $0.2C_5$ to 1.0V

4.2.10 LIFE-SPAN (EXPRESS)

The capacity of the battery shall be $\geq 1350\text{mAh}$ at the 400th discharge cycle under the conditions as follows.

Charge	$1C_5$ for 80 minutes ($-\Delta V = 20\text{ mV}$)
Discharge	$1C_5$ to 1.0V/unit

4.2.11 STORAGE

Within 14 days, the battery shall not cause discoloration, electrolyte, leakage or deformation at $30\text{-}60^\circ\text{C}$ with the relative humidity at 75%-85%.

4.2.12 VIBRATION

The battery shall not cause damage to its performances when tested with the amplitude at 4mm (0.158 inch) and the frequency at 1000Hz.

4.2.13 DROP TEST

The battery shall keep normal when dropped from a height of 1000mm to the wooden board after fully charged.

4.2.14 SHORT CIRCUIT

The fully charged battery shall not explode when shorted directly by wires.

4.2.15 INCORRECT POLARITY CHARGE

Discharge at $0.2C_5$ to the end voltage 0V, then discharge by force at $1C_5$ rate for 60 minutes, and the battery should not explode or break.

5. SUGGESTION & ADVICE

- A. The end-voltage is recommended at $1.0\pm 0.1V$.
- B. The battery may go fail when shorted, over-charged or charged with incorrect polarity.
- C. Avoiding soldering directly to the battery.
- D. Do not dispose of in fire and keep away from damage.

Appendix 1: Dimensions (mm)

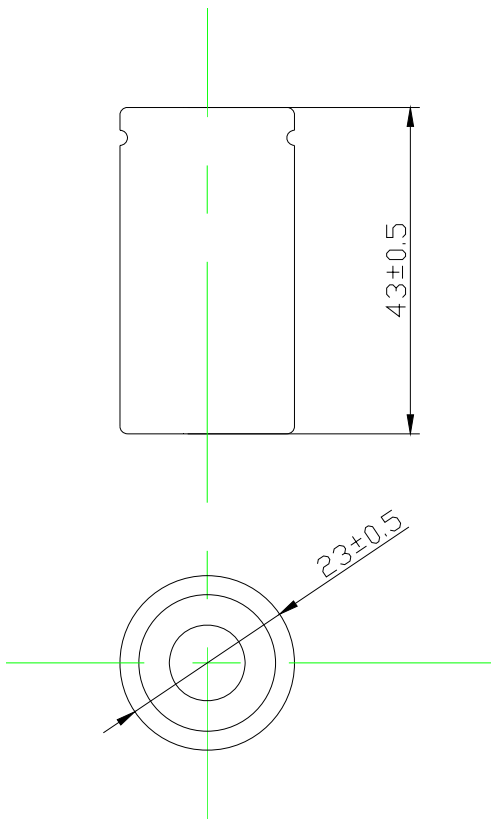

Nominal Specifications

Nominal voltage		1.2V	
Capacity (mAh)	0.2C		10C
	Minimum(min)	285	5.1
	Normal(min)	300	5.4
Diameter		23±0.5mm	
Height		43±0.5mm	
Weight (approx)		44g	
Internal impedance at 1000Hz.		10mΩ (After charge)	
Charge	Standard		180mA×15hrs.
	Quick		1800mA×1.5hrs.
	Trickle	Max.	90mA
Min.		54mA	
Ambient temperature	Charge	Standard	0°C ~ 40°C
		Quick	10°C ~ 40°C
	Discharge		-10°C ~ 50°C
	Storage		-10°C ~ 45°C

Technical curves

